

F10.2

DIAGRAMMA DI CARICO
CAPACITY CHART
DIAGRAMME DE CHARGE
SKIZZE DER HEBEKAPAZITÄT

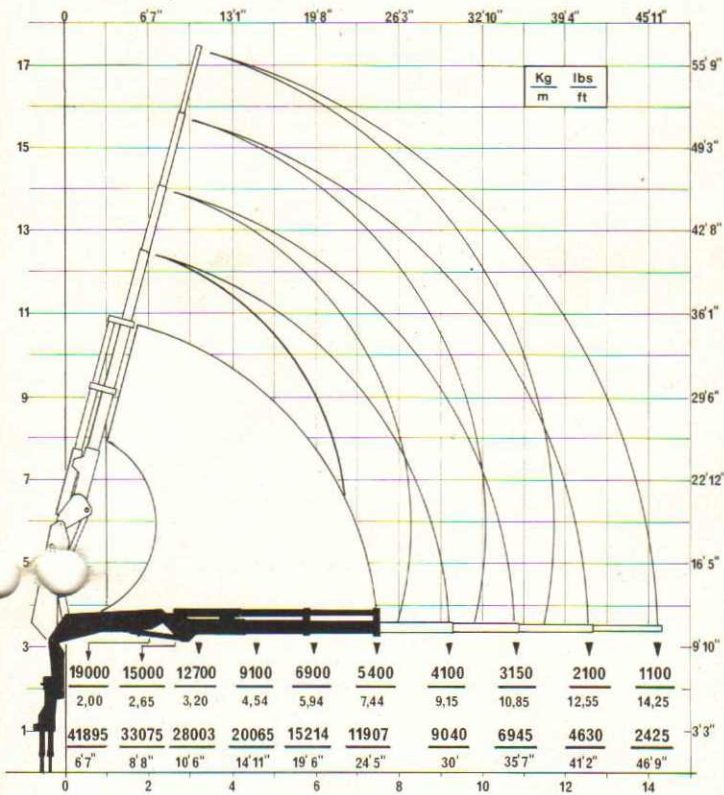

DATI TECNICI TECHNICAL DATA DONNÉES TECHNIQUES TECHNISCHE DATEN	METRIC SYSTEM		AMERICAN MEAS	
	F10.2	F10.3	F10.2	F10.3
Capacità di sollevamento Lifting capacity Capacité de levage Hubvermögen	Kgm		lbs/ft	
	40000		291060	
Sbraccio standard Standard reach Bras standard Standardarm	m	m	ft	ft
	7,44	9,15	24'5"	30'
Estensione idraulica Hydraulic extension Extension hydraulique Hydraulischen Ausschub	m	m	ft	ft
	2,90	4,50	9'6"	14'9"
Angolo di rotazione Slewing arc Rotation Drehwinkel	360° continua		360°	
Coppia di rotazione Rotation torque Couple de rotation Drehmoment	Kpm		lbs/ft	
	4500		32503	
Portata raccomandata della pompa Recommended pump capacity Débit souhaité de la pompe Erforderliche Pumpenleistung	l/min		gal/min	
	50		13	
Pressione d'esercizio Working pressure Pression d'utilisation Betriebsdruck	bar		psi	
	250		3586	
Capacità del serbatoio dell'olio Oil tank capacity Capacité du réservoir d'huile Fassungsvermögen des Öltanks	l		gal	
	220		58	
Peso della gru Crane weight Poids de la grue Kran Gewicht	Kg	Kg	lbs	lbs
	4200	4400	9261	9702
Peso trav. suppl. con stabilizzatori Weight of supplementary outriggers Poids de la traverse supplémentaire Hintere Abstützungen Gewicht	Kg		lbs	
	550		1212	

DIMENSIONI D'INGOMBRO - OVERALL DIMENSIONS
COTES D'ENCOMBREMENT - MASSE

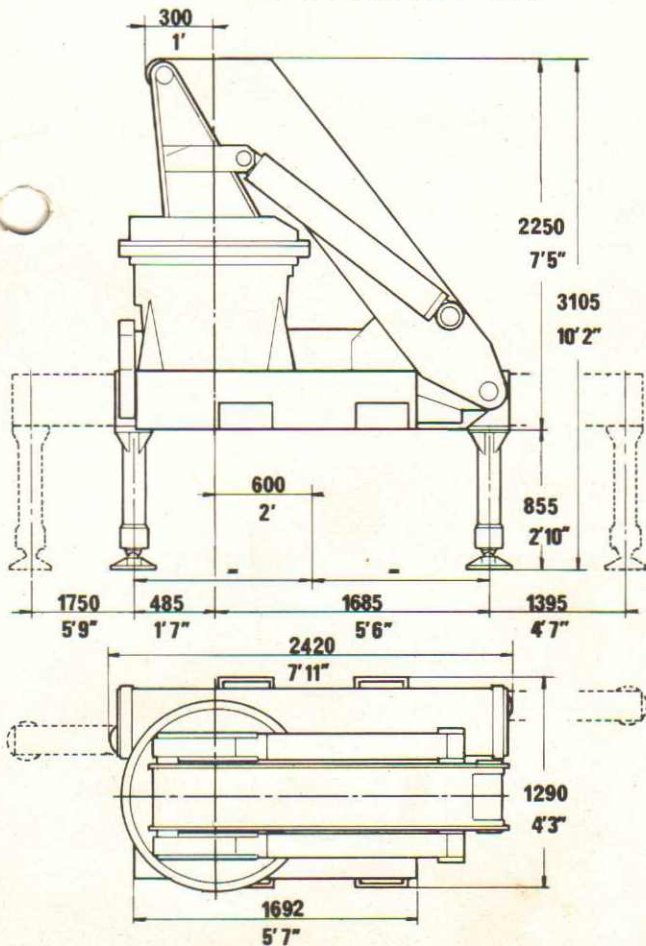

F10.3

DIAGRAMMA DI CARICO
CAPACITY CHART
DIAGRAMME DE CHARGE
SKIZZE DER HEBEKAPAZITÄT

